

Broadband Slim Internal Antenna for Wireless and Satellite Phone Communications

Alireza Bagheri, and Amir Jafargholi

Electromagnetic and Antenna Lab., Amirkabir University of Technology, 424 Hafez Ave., P.O. Box 15875-4413, Tehran, Iran
E-mail: jafargholi@ieee.org (Corresponding author)

ABSTRACT:

A new broadband slim microstrip antenna with a narrow ground plane for GPS (1575.42 MHz), Glonass (1600 MHz), GSM (1800 MHz), LTE (1700 MHz), DAB (1452 MHz) and satellite phone (Iridium, 1616-1626.5 MHz; Inmarsat and Ligado, 1525-1646.5 MHz and Thuraya, 1525-1661 MHz) applications is proposed. The antenna is comprised of a slim rectangular patch, a shorting pin, and a meander-line structure. Its strip-like shape helps to be easily mounted inside the portable devices. The antenna has a dimension of approximately $0.43\lambda \times 0.02\lambda \times 0.008\lambda$ while achieving a gain and an efficiency of 2.4 dB and 95%, respectively. Using a defected ground plane the antenna impedance bandwidth ($|S_{11}| < -6$ dB) of 32.6% from 1.44 to 2 GHz is observed. In order to validate simulation results, a prototype of the proposed printed antenna is fabricated and tested. Good agreement between the simulation and measurement results is obtained.

KEYWORDS: Broadband Antenna, Defected Ground Plane, Slim Antenna, Internal Antenna, Wireless Communication, Satellite Phone Communications

1. INTRODUCTION

The rapid growth of high mobility necessity and multifunctional wireless communication systems, increase the interest for compact, low-profile, integrated and multiband microstrip antennas in recent years [1]-[12]. However, the main difficulties faced engineers to design compact antennas are the bandwidth and efficiency issues [13]. Recently, the new long-term evolution (LTE) has attracted engineers due to the higher speed communication. It is also interesting that the satellite phone terminals support these local cellular networks, i.e. GSM and LTE. Providing intelligent transportation and precise positioning, these portable devices required to support the global positioning system (GPS). Nowadays, increasing demands for compact integrated internal antennas that simply embedded in laptop, tablet, and smartphones have resulted in considerable interest in a research community [14]-[16]. However, almost all of these antennas has a complex structure and an electrically large ground plane [17].

In spite of the prevalent belief that right-hand circular polarization (RHCP) is imperative in GPS antennas, it is well-known that the circularly polarized waves are more sensitive to the multipath fading, while the linearly polarized signal is less affected by the surrounding environment [18]. This paper presents a linearly polarized internal stand-alone slim antenna. The antenna has a broad frequency band while it

compared with the other conventional antennas [19]. The antenna shape makes it capable to be used beside the monitor/LCD in the device enclosure. Antenna prototype is fabricated and measured. Good agreement between the simulation and measurement results is obtained.

2. ANTENNA CONFIGURATION

Please use automatic hyphenation and check your spelling. Additionally, be sure your sentences are complete and that there is continuity within your paragraphs. Check the numbering of your graphics and make sure that all appropriate references are included.

Fig. 1 reveals the schematic of the proposed antenna. The Rogers RO4003 with the permittivity of 3.55 and a thickness of 1.54 mm is utilized as the antenna substrate with the overall dimension of 76×3.5 mm². The antenna comprised of a patch (27×2.6 mm²) and a ground plan. The patch electrically shorts near the antenna edge with a pin (radius of 0.15 mm) and a resonant at 1.85 GHz has been achieved. Changing the shorting pin's location merges this resonant with the antenna resonant frequency of 1.4 GHz, and helps to extend the antenna bandwidth drastically. Moreover, adding a meander-line (ML) structure leads to appear additional resonant at 2.0 GHz. The width of the line and the gaps are equal to 0.2 mm. Defecting the ground plane just underneath the ML structure causes to enhance antenna impedance bandwidth.

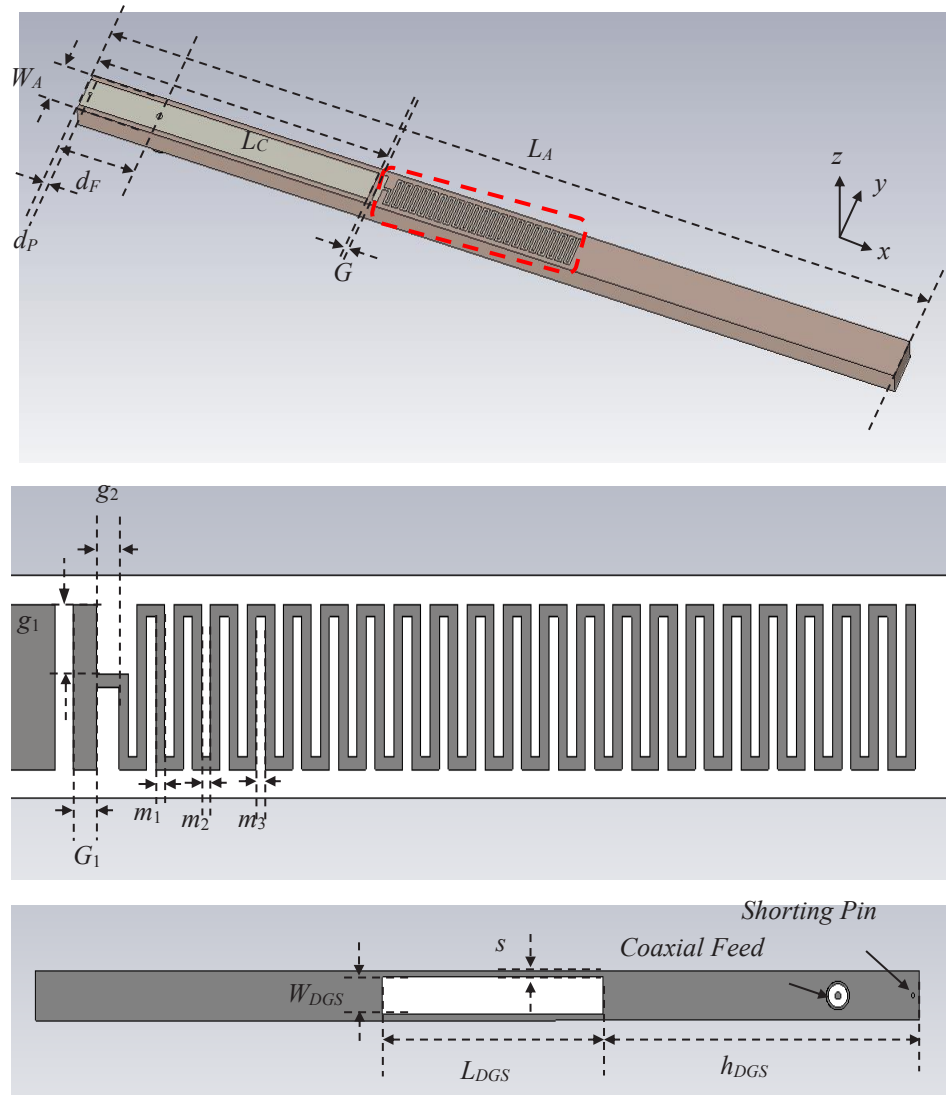

Fig. 1. A schematic view of proposed strip-like antenna (all dimensions are in mm): $L_A=76$, $W_A=3.5$, $L_C=27$, $d_F=0.5$, $d_P=7$, $G=0.4$, $G_1=0.5$, $g_1=1.1$, $g_2=0.5$, $m_1=m_2=m_3=0.2$, $s=1.75$, $h_{DGS}=27.2$, $L_{DGS}=19$, $W_{DGS}=2.6$

3. SIMULATION AND TEST RESULTS

To analyze the operating principle of the antenna, Fig. 2 shows the schematic and simulated antenna input impedance with the main coupled-fed branch only (Ant. I), antenna with the coupled-fed branch plus shorting pin (Ant. II) and the proposed antenna. All three antennas have the same dimensions as depicted in Fig. 1. The shorting pin connects the main strip to the ground plane while it simultaneously has significant effects on impedance matching.

Fig. 2(b) compares the effects of each part on the antenna input impedance. It should be noted that the dimensions of these antennas are the same. The fabricated prototype is illustrated in Fig. 2(c). This figure compares the results of numerical simulation and measured s-parameters. Measurements are in agreement with the simulation results. However, some discrepancy seems especially at the higher band that is

due to the errors attributed to feeding structure, cables, and other practical considerations. According to this figure, a broad operating bandwidth ($|S_{11}| < -6$ dB) of 32.6% from 1.44 to 2 GHz (560 MHz) has been achieved.

Parameter L_{DGS} defines the meander-line length and the defect on the ground plane. This parameter may be adjusted to enhance antenna bandwidth. Fig. 3 shows simulated reflection coefficient of the proposed antenna for different values of L_{DGS} . According to this figure, parameter L_{DGS} could significantly affect the antenna impedance characteristics.

In this figure the antenna return loss as a function of shorting via's location, d_P , is also investigated. According to Fig. 3(b), changing the via's location affects the antenna bandwidth. However, it does not have considerable effect on the lower and upper resonant frequencies.

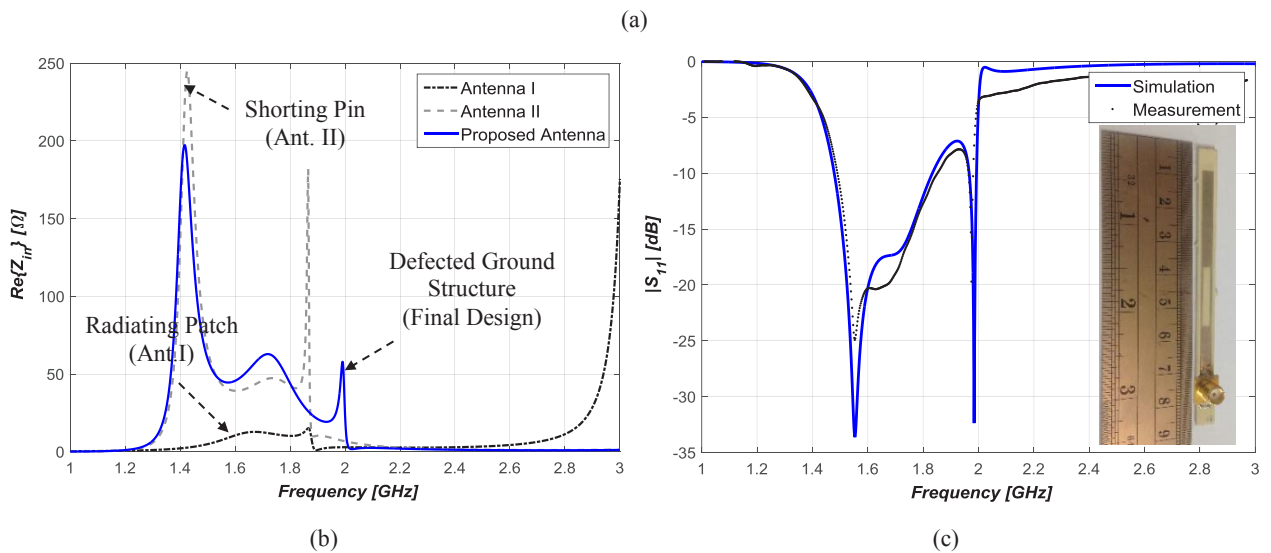
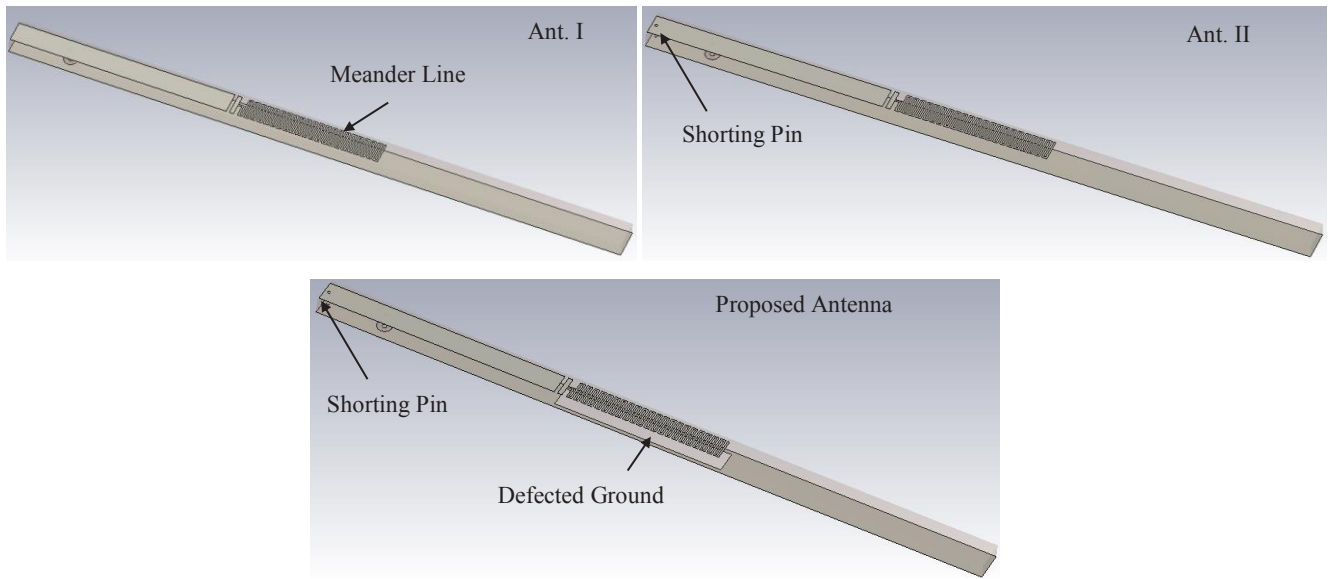

Fig. 2. Comparison of simulated antenna impedance for the main coupled-fed only (Ant. I), antenna with the coupled-fed branch plus shorting pin (Ant. II) and the proposed antenna, (a) schematics, (b) real, and (c) imaginary parts

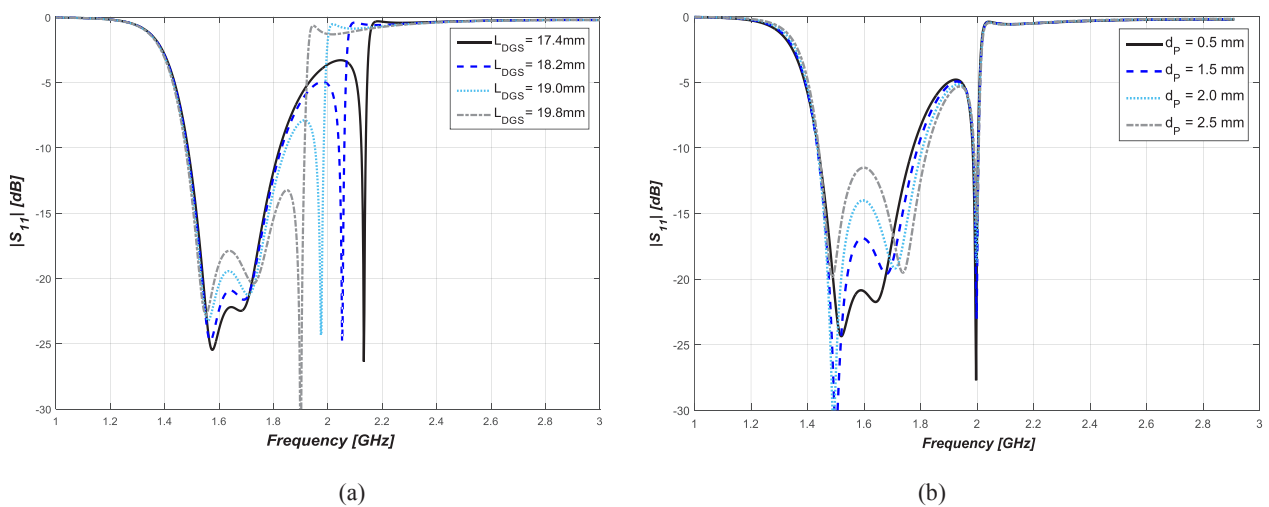

Fig. 3. The simulated reflection coefficient of the proposed antenna for different values of (a) L_{DGS} , and (b) d_P

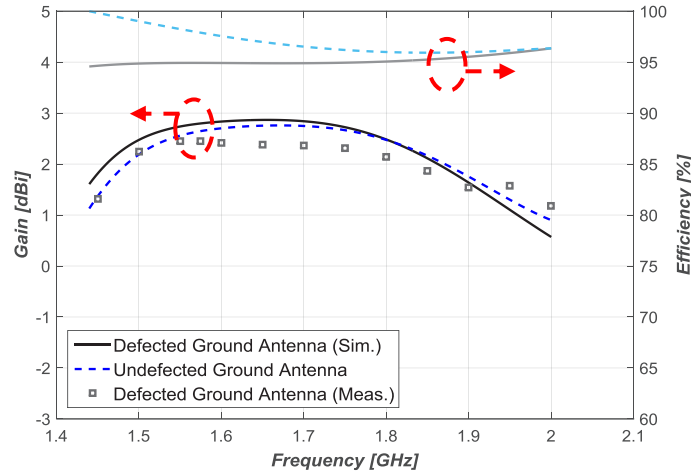

Fig. 4. Comparison between simulation and measurement results of gain and radiation efficiency

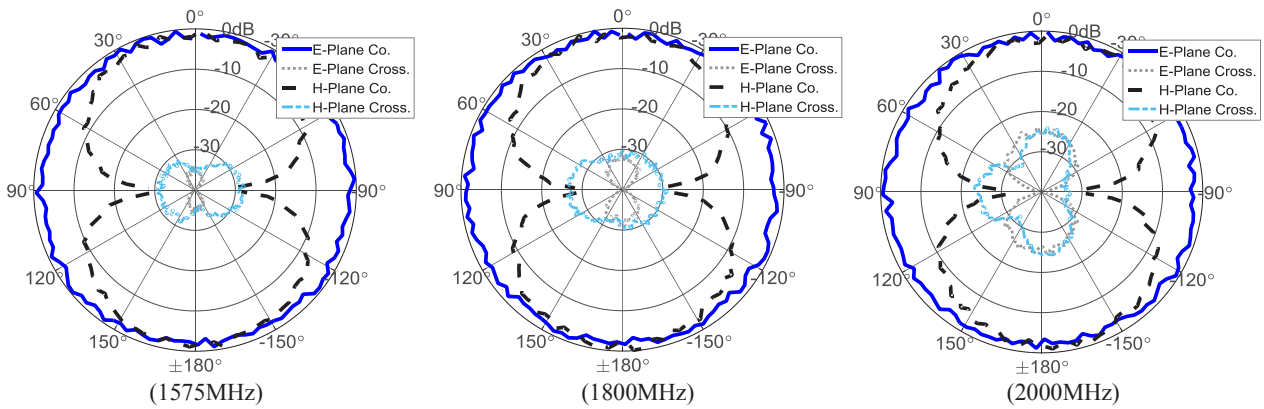

Fig. 5. Measured normalized radiation patterns, at $f= 1575, 1800,$ and 2000 MHz

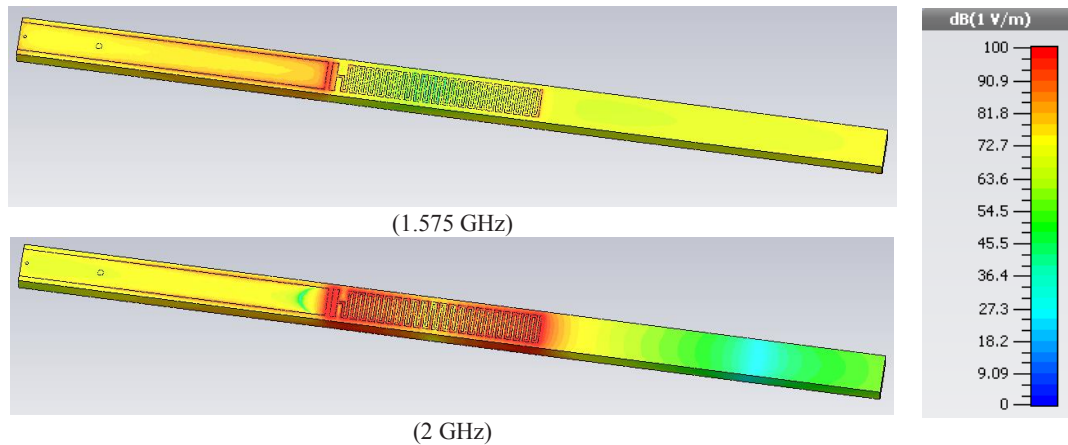

Fig. 6. Tangential electric field distribution, ($|E|$), of proposed antenna at $f=1.575,$ and 2 GHz

Fig. 4 represents the antenna measured gain and simulated efficiency. It is evident from this figure that the antenna efficiency is greater than 95% along with 0.7 to 2.7 dBi gain, which is an appropriate candidate for practical personal applications.

Fig. 5 shows the measured normalized far-field radiation at $f= 1575, 1800$ and 2000 MHz. According to this figure, the antenna has omnidirectional radiation

and a cross-polarization discrimination of 20 to 30 dB. The sleeve balun is fabricated to measure the antenna radiation at these resonant frequencies [20], and [21].

The antenna has two different sections which are utilized for both lower and higher frequencies. In Fig. 6, the tangential component of the electric field of proposed antenna for both low and high frequencies are depicted and compared. As it is illustrated in this

figure, the meander-line is the main radiating part of the antenna at the upper frequencies.

4. CONCLUSION

A new planar linearly polarized internal stand-alone slim antenna covers DAB (1452 MHz), GPS (1575.42 MHz), Glonass (1600 MHz), LTE (1700 MHz), GSM (1800 MHz) and satellite phone (Iridium, 1616-1626.5 MHz; Inmarsat and Ligado, 1525-1646.5 MHz and Thuraya, 1525-1661 MHz) applications has been presented. The antenna has a dipole-like radiation with an overall dimension of $0.43\lambda \times 0.02\lambda \times 0.008\lambda$ while achieving a maximum gain and efficiency of 2.4 dB and 95%, respectively.

REFERENCES

- [1] M. Rafaei Booket, A. Jafarholi, M. Kamyab, H. Eskandari, M. Veysi, and S. M. Mousavi, "A Compact Multi-Band Printed Dipole Antenna Loaded With Single-Cell MTM," *IET Microwave Antenna Propag.*, Vol. 6, No. 1, pp. 17-23, 2012.
- [2] M. Veysi, M. Kamyab, and A. Jafarholi, "Single Feed Dual Band Dual Linearly Polarized Proximity-Coupled Patch Antenna," *IEEE Antenna Propag. Magazine*, Vol. 53, No. 1, 90-96, Feb. 2011.
- [3] A. Jafarholi, M. Kamyab, and M. Veysi, "Artificial Magnetic Conductor Loaded Monopole Antenna," *IEEE Antennas Wireless Propag. Letter*, vol. 9, 211-214, 2010.
- [4] M. Rafaei Booket, M. Kamyab, A. Jafarholi, and S. M. Mousavi, "Analytic Modeling and Implementation of The Printed Dipole Antenna loaded with CRLH Structures," *Progress In Electromagnetic Research B*, Vol. 20, 167-186, 2010.
- [5] P. Forouzaneshad, A. Jafarholi, and A. Jahanbakhshi, "Multiband Compact Antenna for Near-Field and Far-Field RFID and Wireless Portable Applications," *IET Microwave Antenna Propag.*, vol. 11, no. 4, pp. 535-541, 2017.
- [6] M. Rafaei Booket, M. Veysi, Z. Atlasbaf, A. Jafarholi, "Ungrounded Composite Right/Left Handed Metamaterials: Design, Synthesis, and Applications," *IET Microwave Antenna Propag.*, Vol. 6, No. 11, pp. 1259 – 1268, 2012.
- [7] A. Jafarholi, and M. H. Mazaheri, "Broadband Microstrip Antenna Using ENZ Metamaterials," *IET Microwave Antenna Propag.*, vol. 9, no. 14, pp. 1612-1617, 2015.
- [8] A. Jafarholi, M. Kamyab, M. Rafaei Booket, and M. Veysi, "A Compact Dual-band Printed Dipole Antenna Loaded with CLL-Based Metamaterials," *International Review of Electrical Engineering (IREE)*, Vol. 5, No. 6, pp. 2710-2714, 2010.
- [9] M. Veysi, and A. Jafarholi, "Directivity and Bandwidth Enhancement of Proximity-Coupled Microstrip Antenna Using Metamaterial Cover," *Applied Computational Electromagnetics Society, ACES Journal*, Vol 27, No. 11, pp. 925-930, Nov. 2012.
- [10] A. Jafarholi, M. Kamyab, M. Veysi, and M. Nikfal Azar, "Microstrip Gap Proximity Fed-Patch Antennas, Analysis, and Design," *Int. J. Electronics Com., (AEU)* 66 (2012) 115–121.
- [11] A. Jafarholi, and A. Jafarholi, "Miniaturization of Printed Slot Antennas Using Artificial Magnetic Conductors," *IET Microwave Antenna Propag.*, vol. 12, no. 7, pp. 1054-1059, Jun. 2018.
- [12] A. Jafarholi, A. Jafarholi, and B. Ghalamkari, "Dual-Band Slim Microstrip Patch Antennas," *IEEE Trans. Antennas Propagat.*, vol. 66, no. 12, pp. 6818-6825, 2018.
- [13] L. Pazin and Y. Leviatan, "Narrow-Size Multiband Inverted-F Antenna," *IEEE Antennas and Wireless Propagation Letters*, vol. 10, pp. 139-142, 2011.
- [14] N. Amani, A. Jafarholi, "Internal Uni-Planar Antenna for LTE/WWAN/GPS/GLONASS Applications in Tablet/Laptop Computers", *IEEE Antennas Wirel. Propag. Lett.*, vol. 14, pp. 1654-1657, 2015.
- [15] N. Amani, and A. Jafarholi, "Strip-like internal antenna for GPS/Glonass/LTE/GSM/WLAN and near-field applications," *Int. J. Electronics Lett.*, vol. 7, no. 1, pp. 77-84, 2019.
- [16] B. Y. Park, M. H. Jeong and S. O. Park, "A Magneto-Dielectric Handset Antenna for LTE/WWAN/GPS Applications," *IEEE Antennas and Wireless Propagation Letters*, vol. 13, pp. 1482-1485, 2014.
- [17] Y. D. Sim, C. C. Chen, X. Y. Zhang, Y. L. Lee and C. Y. Chiang, "Very Small-Size Uniplanar Printed Monopole Antenna for Dual-Band WLAN Laptop Computer Applications," *IEEE Trans. Antennas Propag.*, vol. 65, no. 6, 2916–2922, 2017.
- [18] V. Pathak, S. Thornwall, M. Krier, S. Rowson, G. Poilasne, and Desclos, "mobile handset system performance comparison of a linearly polarized GPS internal antenna with a circularly polarized antenna", *IEEE Int. Symp. Antennas and Propagation Society*, pp. 666-669, 2003.
- [19] Y. Dong, J. Choi, and T. Itoh, "Folded Strip/Slot Antenna with Extended Bandwidth for WLAN Application," *IEEE Antennas Wireless Propag. Lett.*, vol. 16, 673–676, 2017.
- [20] N. Amani, A. Jafarholi, M. Kamyab and A. Vaziri, "Asymmetrical wideband zeroth-order resonant antenna", *Electronics Letters*, 50 (2), 59-60, 2014.
- [21] N. Amani, M. Kamyab, A. Jafarholi, A. Hosseinbeig, and J. S. Meiguni, "Compact tri-band metamaterial-inspired antenna based on CRLH resonant structures," *Electronics Letters*, 50 (12), 847-848, 2014.